

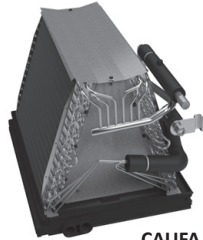

CAPEA / CAPE
Cased with EEV

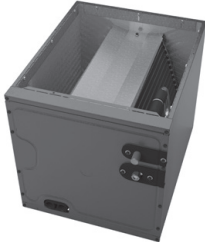

CAUFA
Uncased



CAPFA
Cased



CHPT
Cased with Internal TXV



CAPTA
Cased with Internal TXV



CAPF
Cased



CAUF
Uncased



CHPTA
Cased with Internal TXV



CHPF
Horizontal "A"

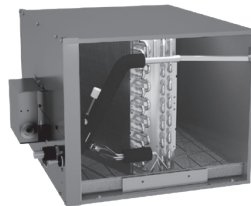

CHPE
Horizontal "A" with EEV



CSCF
Horizontal Slab



CAPT
Cased with Internal TXV



Note: Do not use these coils on oil furnaces or any applications where the temperature on the drain pan may exceed 300° F. If these coils are applied with an oil furnace or another application where high temperatures threaten or jeopardize the durability of the drain pan, you must replace the factory-installed drain pan with a high-temperature drain pan. High-temperature drain pan kits are available as field-installed accessories.

CAPE, CAPEA, CAPT, CAPTA, CAPF, CAPFA, CAUF, CAUFA, CHPE, CHPT, CHPTA, CHPF AND CSCF CASSED, PAINTED UPFLOW/DOWNFLOW, UNCASSED UPFLOW/DOWNFLOW, HORIZONTAL "A", AND HORIZONTAL SLAB

Standard Features

- All-Aluminum evaporator coil
- Optimized for use with R-410A refrigerant
- Some models suitable for use with R-410A or R-22 refrigerant
- CAPE, CAPEA and CHPE models feature:
 - Factory-installed electronic expansion valve (EEV) for precise refrigerant control
 - Compatibility with Daikin *One+* smart thermostat and other Daikin communicating equipment
 - Cooling and heat pump applications
 - Fault recall of six most recent faults
- CAPT, CAPTA, CHPT and CHPTA models feature factory-installed thermal expansion valves for cooling and heat pump applications
- Check flowrator for cooling and heat pump applications
- Vertical and horizontal models available
- 21" depth for easier attic access
- CAPFA/CAPTA/CHPTA/CAPEA models include a single front access panel
- Foil-faced insulation covers the internal casing to reduce cabinet condensation
- Galvanized, leather grain-embossed finish
- Rust resistant, thermoplastic drain pans featuring a low water-retention design
- DecaBDE-free thermoplastic drain pan with secondary drain connections
- UV-resistant drain pan
- AHRI certified; ETL listed



* Complete warranty details available from your local dealer or at www.daikincomfort.com. To receive the 12-Year Parts Limited Warranty, online registration must be completed within 60 days of installation. Online registration is not required in California or Québec.

NOMENCLATURE

	C	A	U	F	1824	A	6	AA
	1	2	3	4	5,6,7,8	9	10	11, 12
Product Category								
C Indoor Coil								
Application								
A Upflow/Downflow Coil								
H Horizontal A Coil								
S Horizontal Slab Coil								
Cabinet Finish								
U Uncased								
P Cased- Painted								
C Cased- Unpainted								
Expansion Device								
F Flowrater								
T TXV								
E Electronic Expansion Valve								
	Engineering							
	Major/ Minor Revisions							
	Refrigerant							
	6- R-22 / R-410A							
	4- R-410A							
	Nominal Width for Gas Furnace							
	A- Fits 14" Furnace Cabinet							
	B- Fits 17½" Furnace Cabinet							
	C- Fits 21" Furnace Cabinet							
	D- Fits 24½" Furnace Cabinet							
	N-Does Not Apply (horizontal slab coil)							
	Nominal Capacity Range							
	1824- 1½ to 2 Tons				3642- 3 to 3½ Tons			
	3030- 2½ Tons				3743- 3 to 3½ Tons			
	3131- 2½ Tons				4860- 4 to 5 Tons			
	3137- 2½ to 3 Tons				4961- 4 to 5 Tons			
	3636- 3 Tons							

	C	A	P	E	A	1	8	1	4	A	6	A	A
	1	2	3	4	5	6	7	8	9	10	11	12	13
Product Category													
C Indoor Coil													
Application													
A Upflow/Downflow Coil													
H Horizontal A Coil													
S Horizontal Slab Coil													
Cabinet Finish													
U Uncased													
P Cased- Painted													
C Cased- Unpainted													
Expansion Device													
F Flowrater													
T TXV													
E Electronic Expansion Valve													
	Engineering												
	Major/ Minor Revisions												
	Refrigerant												
	4- R-410A only												
	Nominal Width for Gas Furnace												
							A- 14" Width			D- 24.5" Width			
							B- 17½" Width			N- Not Applicable (Slab Coil)			
							C- 21" Width						
	Cased Height												
							14- 14" Coil			22- 22" Coil			
							18- 18" Coil			26- 26" Coil			
										30- 30" Coil			
	Nominal Capacity Range												
	17, 18- 1½- 2 Tons				29, 30- 2- 3 Tons				42- 3- 3½ Tons				
	23, 24- 1½- 2½ Tons				35, 36- 2- 3 Tons				48- 4 Tons				
									60- 5 Tons				

CAUF — UNCASSED UPFLOW/DOWNFLOW INDOOR COILS



SPECIFICATIONS

MODEL	DIMENSIONS			NOMINAL TONS	CONNECTION		PISTON SIZE* (IN.)	SHIP WEIGHT (LBS)
	W	H	A		LIQUID	SUCTION		
CAUF1824A6	13"	16¼"	13"	1½-2	¾"	¾"	.059	18
CAUF1824B6	16½"	16⅞"	13"	1½-2	¾"	¾"	.059	23
CAUF1824C6	20"	16⅞"	17"	1½-2	¾"	¾"	.059	27
CAUF3030A6	13"	20⅞"	17"	2½	¾"	¾"	.065	25
CAUF3030B6	16½"	18¾"	17"	2½	¾"	¾"	.065	22
CAUF3030C6	20"	17⅞"	17"	2½	¾"	¾"	.065	25
CAUF3030D6	23"	17⅞"	17"	2½	¾"	¾"	.065	32
CAUF3131B6	16½"	20⅞"	17"	2½	¾"	¾"	.068	27
CAUF3137B6	16½"	27"	25"	2½-3	¾"	¾"	.071	53
CAUF3131C6	20"	20"	17"	2½	¾"	¾"	.068	31
CAUF3636A6	13"	19½"	17"	3	¾"	¾"	.071	30
CAUF3636B6	16½"	19⅞"	17"	3	¾"	¾"	.071	25
CAUF3636C6	20"	19⅞"	17"	3	¾"	¾"	.071	28
CAUF3636D6	23"	19⅞"	17"	3	¾"	¾"	.071	36
CAUF3642C6	20"	19"	17"	3-3½	¾"	¾"	.078	29
CAUF3642D6	23"	19⅞"	17"	3-3½	¾"	¾"	.078	34
CAUF3743C6	20"	28⅞"	25"	3-3½	¾"	⅞"	.078	46
CAUF3743D6	23"	27⅞"	25"	3-3½	¾"	⅞"	.078	43
CAUF4860C6	20"	28"	25"	4-5	¾"	⅞"	.093	48
CAUF4860D6	23"	28"	25"	4-5	¾"	⅞"	.093	39
CAUF4961C6	20"	28"	25"	4-5	¾"	⅞"	.093	54
CAUF4961D6	23"	27"	25"	4-5	¾"	⅞"	.093	59

* Shipped with Coil

Note: For a properly matched system and piston sizing information, refer to Daikin piston kit chart of the corresponding Daikin outdoor unit.

DIMENSIONS

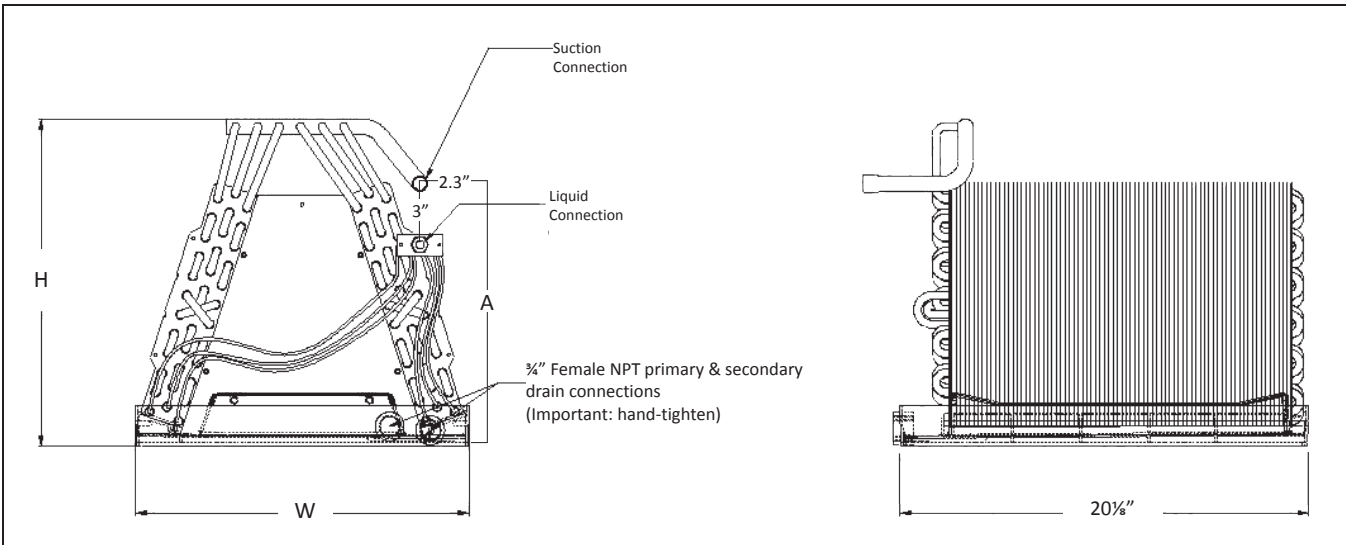

CAUFA — UNCASED UPFLOW/DOWNFLOW INDOOR COILS



SPECIFICATIONS

MODEL	DIMENSIONS				NOMINAL TONS	CONNECTION		PISTON SIZE* (IN.)	SHIP WEIGHT (LBS)
	W	D	H	A		LIQUID	SUCTION		
CAUFA1714A6	12½"	20¾"	11¼"	6"	1½	⅜"	¾"	0.051	16
CAUFA1714B6	16"	20¾"	11"	6"	1½	⅜"	¾"	0.051	18
CAUFA1818A6	12½"	20¾"	14¾"	12¾"	1½	⅜"	¾"	0.055	18
CAUFA1818B6	16"	20¾"	14½"	12¾"	1½	⅜"	¾"	0.055	20
CAUFA1818C6	19½"	20¾"	14¾"	12¾"	1½	⅜"	¾"	0.055	26
CAUFA2318A6	12½"	20¾"	14¾"	12¾"	2	⅜"	¾"	0.057	18
CAUFA2318B6	16"	20¾"	14½"	12¾"	2	⅜"	¾"	0.057	20
CAUFA2318C6	19½"	20¾"	14¾"	12¾"	2	⅜"	¾"	0.057	26
CAUFA2418A6	12½"	20¾"	14¾"	12¾"	2	⅜"	¾"	0.057	18
CAUFA2418B6	16"	20¾"	14½"	12¾"	2	⅜"	¾"	0.057	20
CAUFA2418C6	19½"	20¾"	14¾"	12¾"	2	⅜"	¾"	0.057	26
CAUFA2422A6	12½"	20¾"	18"	17"	2	⅜"	¾"	0.059	26
CAUFA2422B6	16"	20¾"	17¾"	16¾"	2	⅜"	¾"	0.059	28
CAUFA2422C6	19½"	20¾"	17½"	16¾"	2	⅜"	¾"	0.059	30
CAUFA2922A6	12½"	20¾"	18"	17"	2½	⅜"	¾"	0.065	26
CAUFA2922B6	16"	20¾"	17¾"	16¾"	2½	⅜"	¾"	0.065	28
CAUFA2922C6	19½"	20¾"	17¾"	16¾"	2½	⅜"	¾"	0.065	30
CAUFA3022A6	12½"	20¾"	18"	17"	2½	⅜"	¾"	0.063	26
CAUFA3022B6	16"	20¾"	17¾"	16¾"	2½	⅜"	¾"	0.063	28
CAUFA3022C6	19½"	20¾"	17½"	16¾"	2½	⅜"	¾"	0.063	30
CAUFA3022D6	23"	20¾"	17¾"	16¾"	2½	⅜"	¾"	0.063	32
CAUFA3526B6	16"	20¾"	21"	20¾"	3	⅜"	⅞"	0.065	30
CAUFA3526C6	19½"	20¾"	20¾"	20¾"	3	⅜"	⅞"	0.065	31
CAUFA3626B6	16"	20¾"	21"	20¾"	3	⅜"	⅞"	0.065	30
CAUFA3626C6	19½"	20¾"	20¾"	20¾"	3	⅜"	⅞"	0.065	31
CAUFA3626D6	23"	20¾"	20¾"	20¾"	3	⅜"	⅞"	0.065	35
CAUFA4226B6	16"	20¾"	24¾"	20¾"	3½	⅜"	⅞"	0.071	28
CAUFA4226C6	19½"	20¾"	24"	20¾"	3½	⅜"	⅞"	0.071	30
CAUFA4226D6	23"	20¾"	23¾"	20¾"	3½	⅜"	⅞"	0.071	33

* Shipped with Coil

Note: For a properly matched system and piston sizing information, refer to Daikin piston kit chart of the corresponding Daikin outdoor unit.

DIMENSIONS

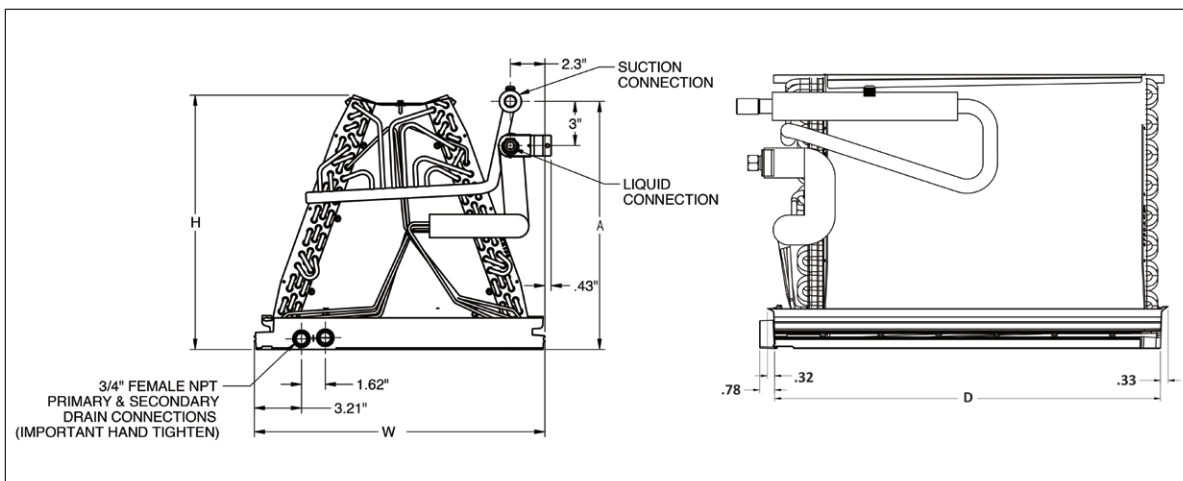

CAPFA — CASED UPFLOW/DOWNFLOW INDOOR COILS



SPECIFICATIONS

MODEL	CABINET DIMENSIONS				NOMINAL TONS	CONNECTION		PISTON SIZE* (IN.)	SHIP WEIGHT (LBS)
	W	D	H	A		LIQUID	SUCTION		
CAPFA1818A6	14"	21"	18"	14"	1½	⅜"	¼"	0.055	33
CAPFA1818B6	17½"	21"	18"	14"	1½	⅜"	¼"	0.055	38
CAPFA1818C6	21"	21"	18"	14"	1½	⅜"	¼"	0.055	43
CAPFA2418A6	14"	21"	18"	14"	2	⅜"	¼"	0.057	33
CAPFA2418B6	17½"	21"	18"	14"	2	⅜"	¼"	0.057	38
CAPFA2418C6	21"	21"	18"	14"	2	⅜"	¼"	0.057	43
CAPFA2422A6	14"	21"	22"	18"	2	⅜"	¼"	0.059	41
CAPFA2422B6	17½"	21"	22"	18"	2	⅜"	¼"	0.059	45
CAPFA2422C6	21"	21"	22"	18"	2	⅜"	¼"	0.059	50
CAPFA3022A6	14"	21"	22"	18"	2½	⅜"	¼"	0.063	41
CAPFA3022B6	17½"	21"	22"	18"	2½	⅜"	¼"	0.063	45
CAPFA3022C6	21"	21"	22"	18"	2½	⅜"	¼"	0.063	50
CAPFA3022D6	24½"	21"	22"	18"	2½	⅜"	¼"	0.063	52
CAPFA3626B6	17½"	21"	26"	22"	3	⅜"	⅞"	0.065	47
CAPFA3626C6	21"	21"	26"	22"	3	⅜"	⅞"	0.065	49
CAPFA3626D6	24½"	21"	26"	22"	3	⅜"	⅞"	0.065	56
CAPFA4226B6	17½"	21"	26"	22"	3½	⅜"	⅞"	0.071	51
CAPFA4226C6	21"	21"	26"	22"	3½	⅜"	⅞"	0.071	54
CAPFA4226D6	24½"	21"	26"	22"	3½	⅜"	⅞"	0.071	59

* Shipped with Coil

Note: For a properly matched system and piston sizing information, refer to Daikin piston kit chart of the corresponding Daikin outdoor unit.

DIMENSIONS

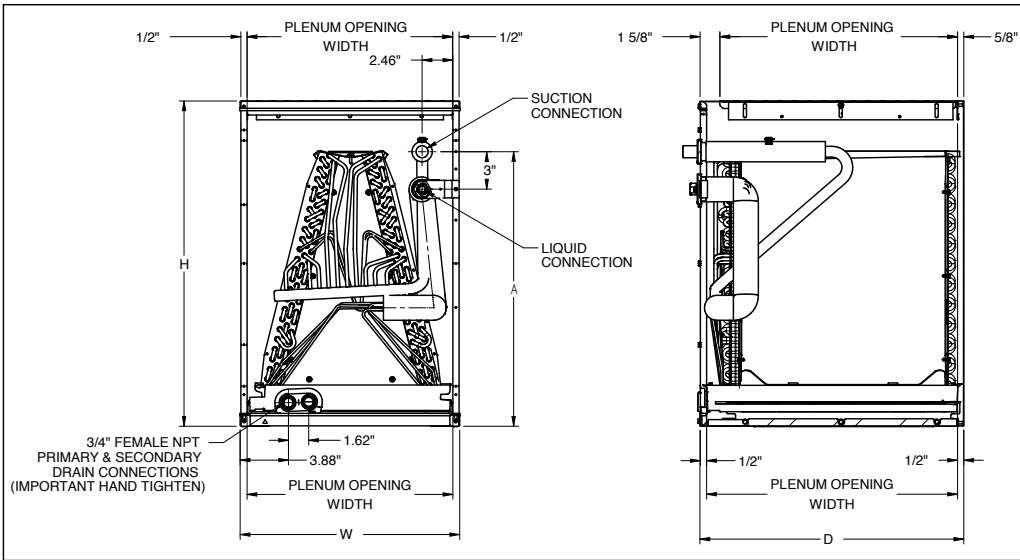

CAPF — CASED UPFLOW/DOWNFLOW INDOOR COILS



SPECIFICATIONS

MODEL	CABINET DIMENSIONS			NOMINAL TONS	CONNECTION		PISTON SIZE* (IN.)	SHIP WEIGHT (LBS)
	W	D	H		LIQUID	SUCTION		
CAPF3137B6	17½"	21"	30"	2½-3	¾"	¾"	.071	53
CAPF3743C6	21"	21"	30"	3-3½	¾"	¾"	.078	63
CAPF3743D6	24½"	21"	30"	3-3½	¾"	¾"	.078	75
CAPF4860C6	21"	21"	30"	4-5	¾"	¾"	.093	65
CAPF4860D6	24½"	21"	30"	4-5	¾"	¾"	.093	68
CAPF4961C6	21"	21"	30"	4-5	¾"	¾"	.093	73
CAPF4961D6	24½"	21"	30"	4-5	¾"	¾"	.093	76

* Shipped with Coil

Note: For a properly matched system and piston sizing information, refer to Daikin piston kit chart of the corresponding Daikin outdoor unit.

DIMENSIONS

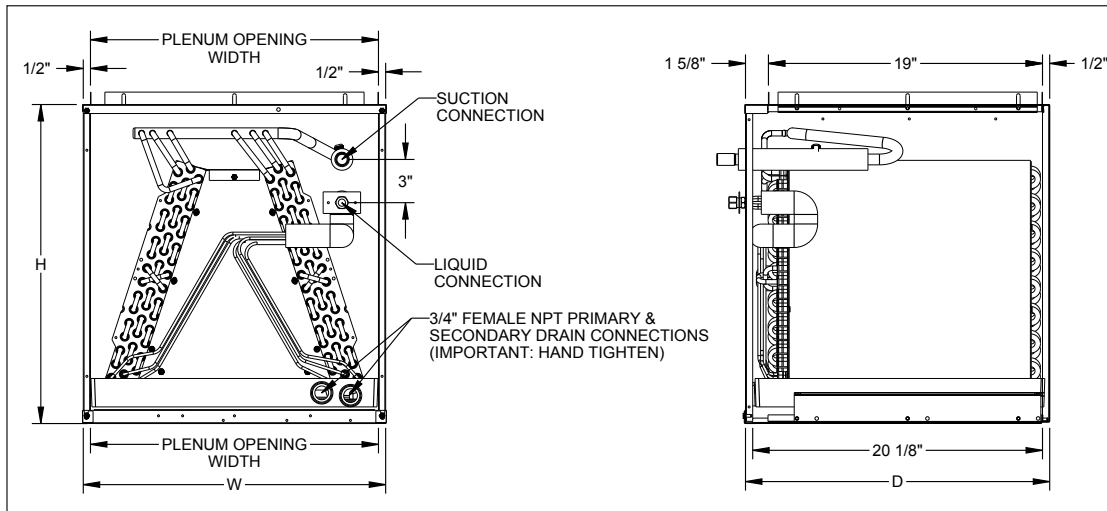

CAPEA / CAPE — CASED UPFLOW/DOWNFLOW INDOOR COILS



SPECIFICATIONS

MODEL	CABINET DIMENSIONS			NOMINAL TONS	CONNECTION		SHIP WEIGHT (LBS)
	W	D	H		LIQUID	SUCTION	
CAPEA1818B4	17½"	21"	18"	1½-2	¾"	¾"	43
CAPEA1818C4	21"	21"	18"	1½-2	¾"	¾"	45
CAPEA2422B4	17½"	21"	22"	2-2½	¾"	¾"	48
CAPEA2422C4	21"	21"	22"	2-2½	¾"	¾"	51
CAPEA3026B4	17½"	21"	26"	3	¾"	7/8"	54
CAPEA3026C4	21"	21"	26"	3	¾"	7/8"	57
CAPEA3026D4	24½"	21"	26"	3	¾"	7/8"	62
CAPEA4830C4	21"	21"	30"	3½- 4	¾"	7/8" or 1½"	67
CAPEA6030D4	24½"	21"	30"	4-5	¾"	7/8" or 1½"	76

MODEL	CABINET DIMENSIONS			NOMINAL TONS	CONNECTION		SHIP WEIGHT (LBS)
	W	D	H		LIQUID	SUCTION	
CAPE4860C4	21"	21"	30"	3½-4	¾"	7/8"	71
CAPE4860D4	24½"	21"	30"	3½-4	¾"	7/8"	73
CAPE4961C4	21"	21"	30"	4-5	¾"	7/8"	78
CAPE4961D4	24½"	21"	30"	4-5	¾"	7/8"	80

DIMENSIONS

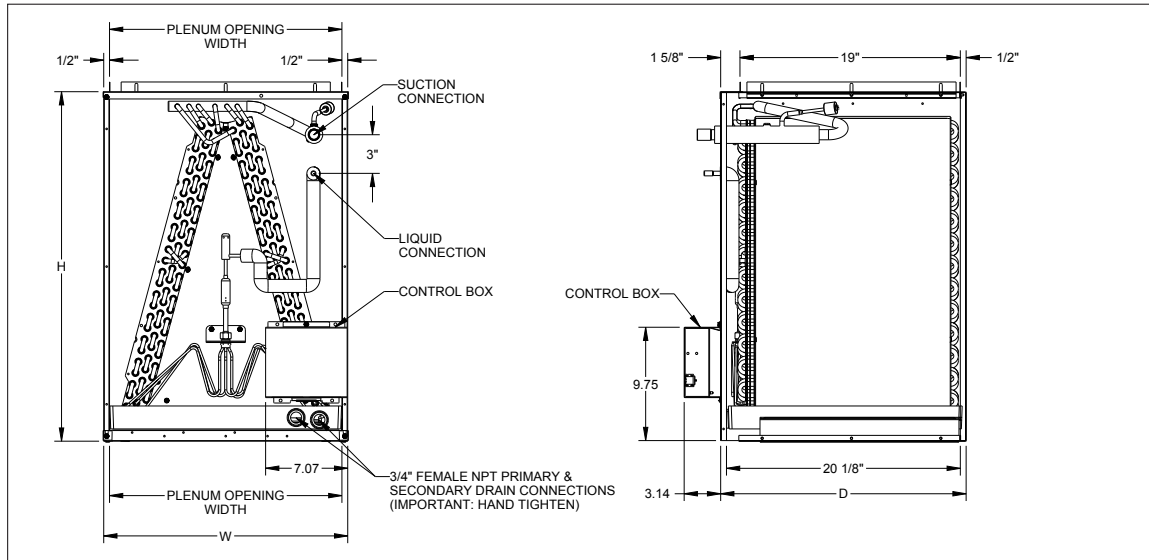
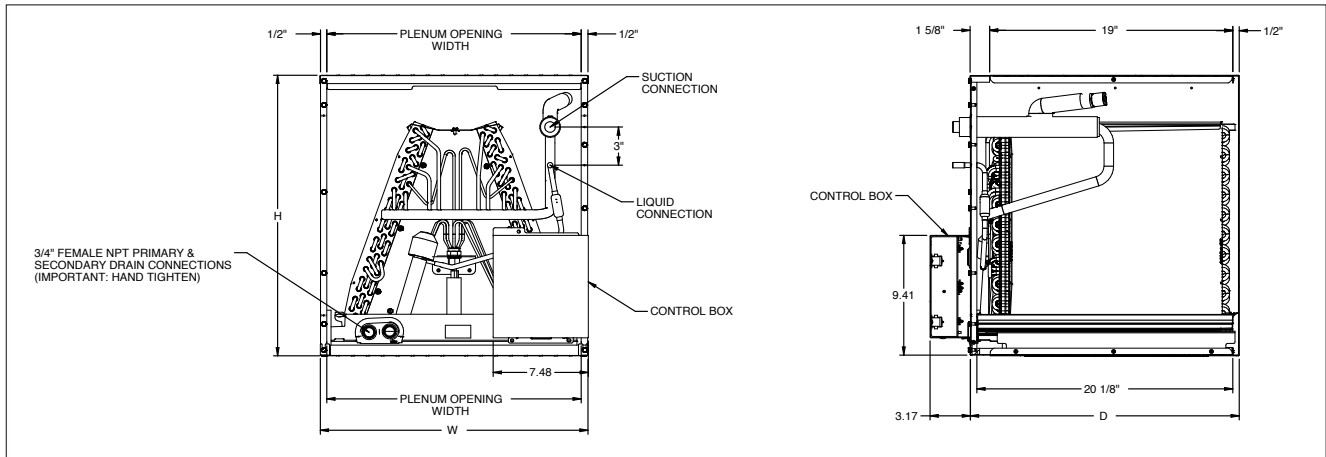

CAPT — CASED UPFLOW/DOWNFLOW INDOOR COILS WITH INTERNAL TXV



SPECIFICATIONS

MODEL	CABINET DIMENSIONS			NOMINAL TONS	CONNECTION		SHIP WEIGHT (LBS)
	W	D	H		LIQUID	SUCTION	
CAPT4961C4	21"	21"	30"	4-5	3/8"	7/8"	73
CAPT4961D4	24 1/2"	21"	30"	4-5	3/8"	7/8"	76

DIMENSIONS

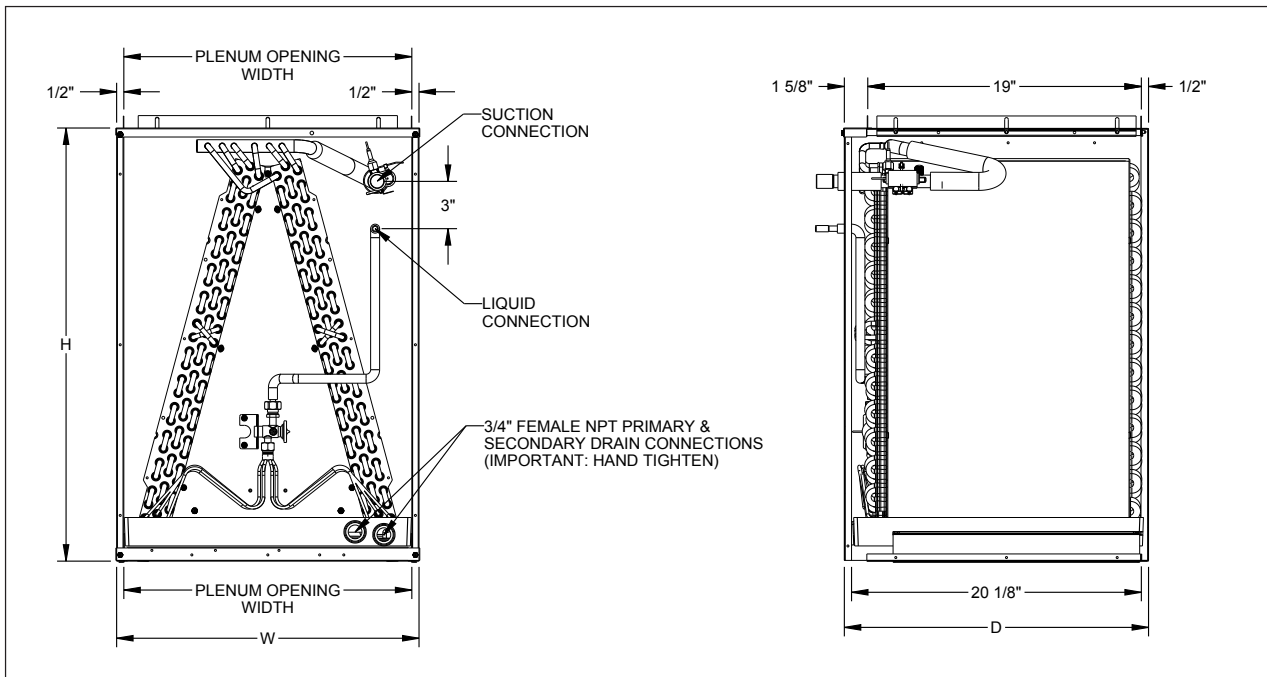

CHPF, CHPE — PAINTED CASED HORIZONTAL “A” INDOOR COIL



SPECIFICATIONS

MODEL	CABINET DIMENSIONS			PLENUM		NOMINAL TONS	CONNECTION		PISTON SIZE (IN.) ²	SHIP WEIGHT (LBS)
	D	W	H	D	H		LIQUID	SUCTION		
CHPF1824A6	21½"	26"	14"	19"	13"	1½-2	⅜"	¼"	.059	36
CHPF2430B6	21½"	26"	17½"	19"	16½"	2-2½	⅜"	¼"	.065	55
CHPF3636B6	21½"	26"	17½"	19"	16½"	3	⅜"	¼"	.074	50
CHPF3642C6	21½"	26"	21"	19"	20"	3-3½	⅜"	¼"	.076	63
CHPF3743C6	21½"	26"	21"	19"	20"	3-3½	⅜"	⅞"	.076	63
CHPF4860D6	21½"	26"	24½"	19"	23½"	4-5	⅜"	⅞"	.093	77

¹ (ft²)

² Shipped with Coil

Note: For a properly matched system and piston sizing information, refer to Daikin piston kit chart of the corresponding Daikin outdoor unit.

MODEL	CABINET DIMENSIONS			PLENUM		NOMINAL TONS	CONNECTION		PISTON SIZE (IN.) ²	SHIP WEIGHT (LBS)
	D	W	H	D	H		LIQUID	SUCTION		
CHPE2430B4	21½"	26"	17½"	19"	16½"	1½	⅜"	¼"	N/A	56
CHPE3636B4	21½"	26"	17½"	19"	16½"	2-3	⅜"	¼"	N/A	59
CHPE3642C4	21½"	26"	21"	19"	20"	2-2 ½	⅜"	¼"	N/A	62
CHPE3743C4	21½"	26"	21"	19"	20"	3-4	⅜"	⅞"	N/A	68
CHPE3743D4	21½"	26"	24½"	19"	23½"	3-3½	⅜"	⅞"	N/A	72
CHPE4860D4	21½"	26"	24½"	19"	23½"	4-5	⅜"	⅞"	N/A	79

DIMENSIONS

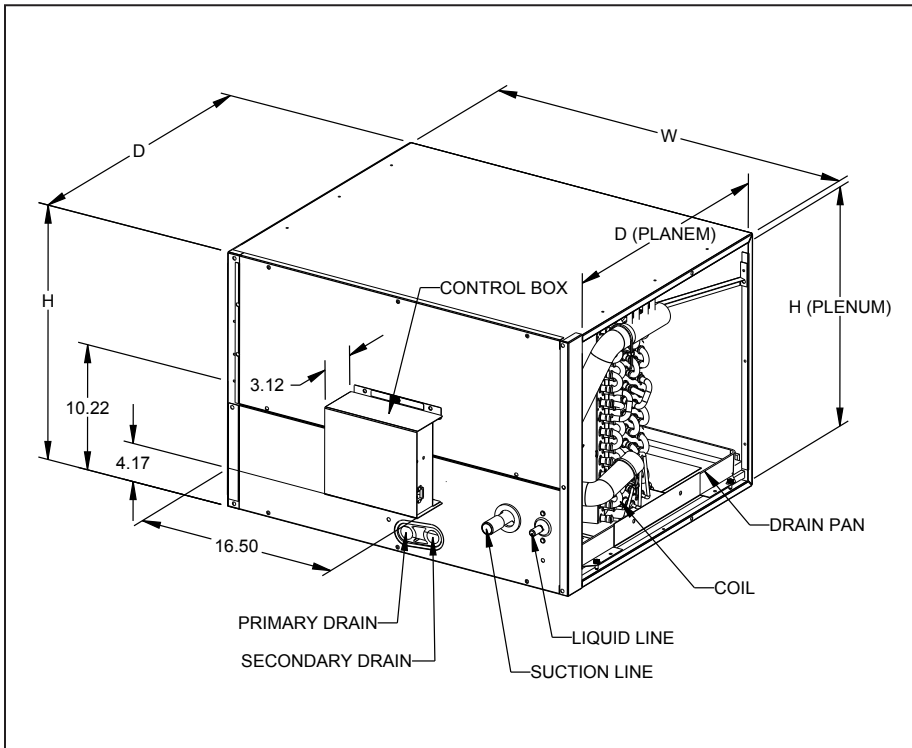

CSCF — HORIZONTAL SLAB EVAPORATOR COILS



SPECIFICATIONS

MODEL	CAPACITY (TONS)	EVAP COIL FACE AREA ¹	CONNECTION SIZE		PISTON SIZE (IN.)*	SHIP WEIGHT (LBS)
			LIQUID	SUCTION		
CSCF1824N6	1½-2	3⅔	⅜"	¼"	.059	43
CSCF3036N6	2½-3	4⅔	⅝"	⅞"	.074	52.5
CSCF3642N6	3-3½	5⅔	⅝"	⅞"	.078	43
CSCF4860N6	4-5	5⅔	⅝"	⅞"	.093	60

* Shipped with Coil

Note: For a properly matched system and piston sizing information, refer to Daikin piston kit chart of the corresponding Daikin outdoor unit.

DIMENSIONS

MODEL	CABINET DIMENSIONS			PLENUM OPENING	
	D (A)	W	H	D (B)	H
CSCF1824N6	25½"	12"	25"	16"	21"
CSCF3036N6	33½"	12"	25"	24"	21"
CSCF3642N6	39½"	12"	25"	30"	21"
CSCF4860N6	39½"	12"	25"	30"	21"

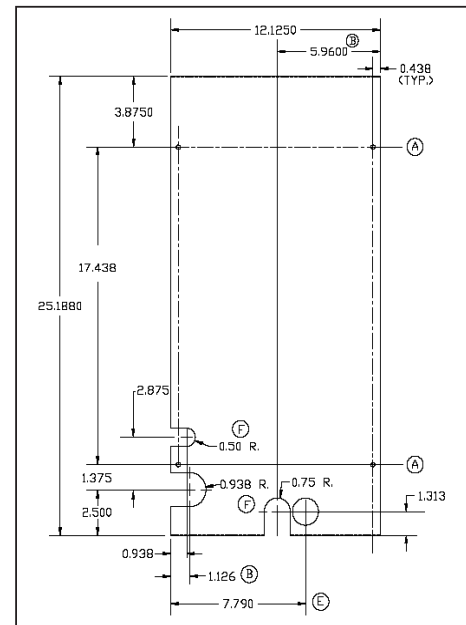
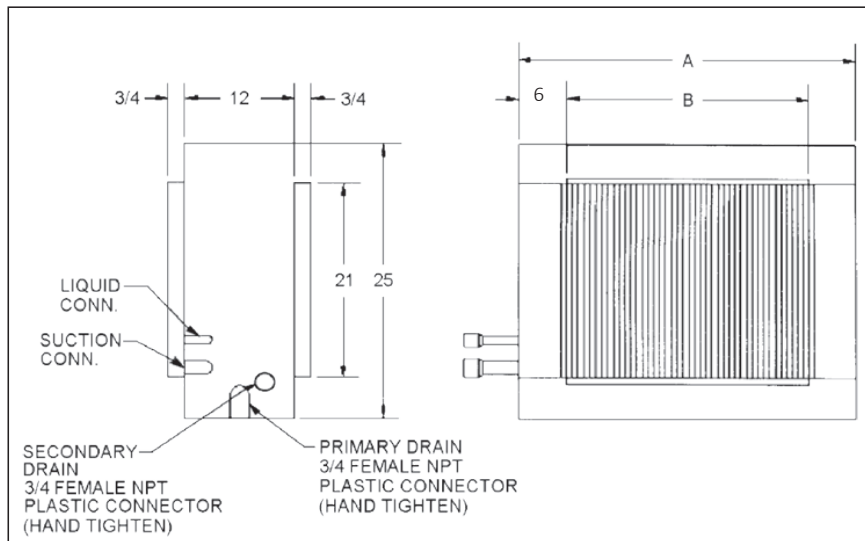

DETAIL OF ACCESS DOOR

CAPTA — CASED UPFLOW/DOWNFLOW INDOOR COILS



SPECIFICATIONS

MODEL	CABINET DIMENSIONS			NOMINAL TONS	CONNECTION		SHIP WEIGHT (LBS)
	W	D	H		LIQUID	SUCTION	
CAPTA1818A4	14"	21"	18"	1½	⅜"	¼"	36
CAPTA1818B4	17½"	21"	18"	1½	⅜"	¼"	41
CAPTA2422A4	14"	21"	22"	2	⅜"	¼"	44
CAPTA2422B4	17½"	21"	22"	2	⅜"	¼"	48
CAPTA2422C4	21"	21"	22"	2	⅜"	¼"	53
CAPTA3022A4	14"	21"	22"	2½	⅜"	¼"	44
CAPTA3022B4	17½"	21"	22"	2½	⅜"	¼"	48
CAPTA3022C4	21"	21"	22"	2½	⅜"	¼"	53
CAPTA3026B4	17½"	21"	26"	2½	⅜"	⅞"	50
CAPTA3026C4	21"	21"	26"	2½	⅜"	⅞"	52
CAPTA3626B4	17½"	21"	26"	3	⅜"	⅞"	54
CAPTA3626C4	21"	21"	26"	3	⅜"	⅞"	57
CAPTA4230C4	21"	21"	30"	3½	⅜"	⅞"	63
CAPTA4230D4	24.5"	21"	30"	3½	⅜"	⅞"	66

Note: For a properly matched system and piston sizing information, refer to Daikin piston kit chart of the corresponding Daikin outdoor unit.

DIMENSIONS

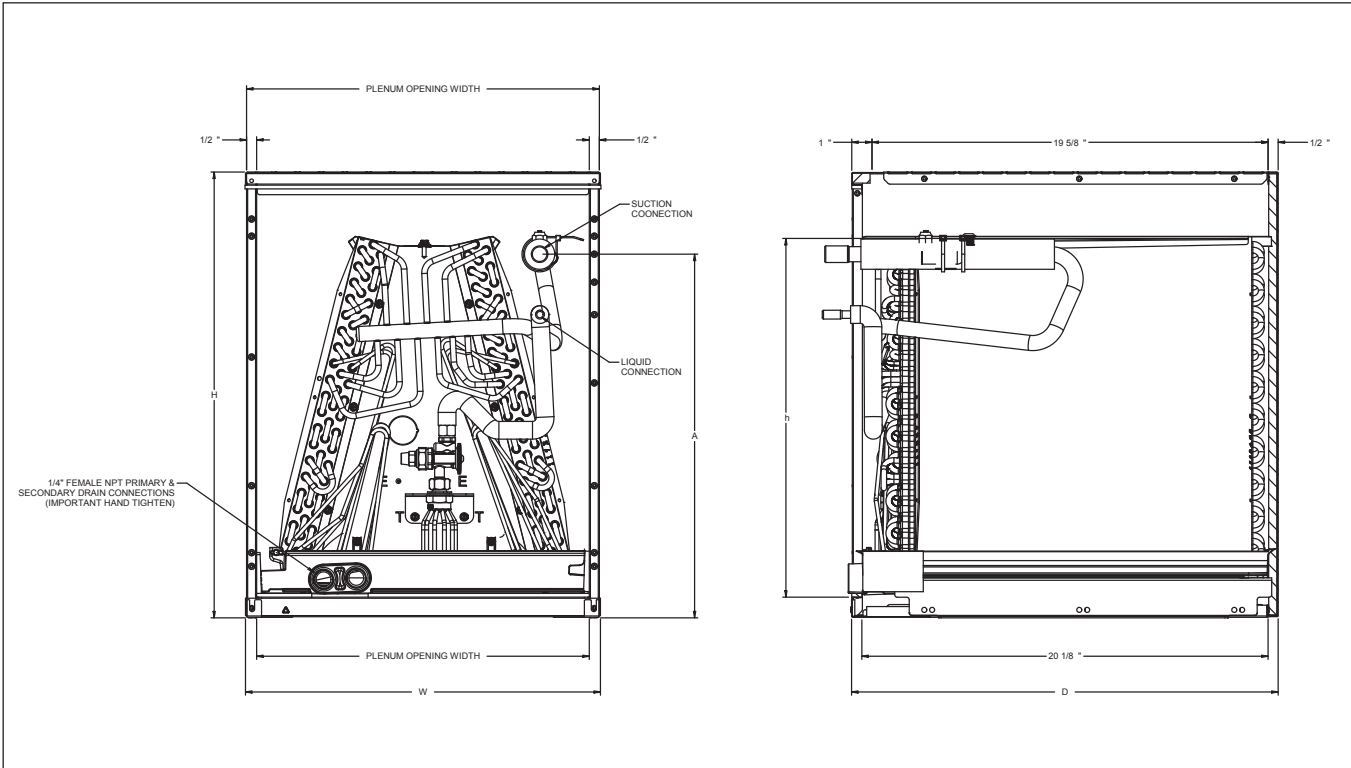

CHPTA, CHPT— CASED HORIZONTAL INDOOR COILS



SPECIFICATIONS

MODEL	CABINET DIMENSIONS			NOMINAL TONS	CONNECTION		SHIP WEIGHT (LBS)
	W	D	H		LIQUID	SUCTION	
CHPTA1822A4	22"	21"	14"	1½	¾"	¾"	48
CHPTA1822B4	22"	21"	17½"	1½	¾"	¾"	52
CHPTA2426B4	26"	21"	17½"	2	¾"	7⁄8"	57
CHPTA2426C4	26"	21"	21"	2	¾"	7⁄8"	59
CHPTA3026B4	26"	21"	17½"	2½	¾"	7⁄8"	61
CHPTA3026C4	26"	21"	21"	2½	¾"	7⁄8"	64
CHPTA3630B4	30"	21"	17½"	3	¾"	7⁄8"	66
CHPTA3630C4	30"	21"	21"	3	¾"	7⁄8"	70
CHPT4860D4**	26"	21¾"	24½"	3½- 5	¾"	7⁄8"	81

Note: For a properly matched system and piston sizing information, refer to Daikin piston kit chart of the corresponding Daikin outdoor unit.

DIMENSIONS

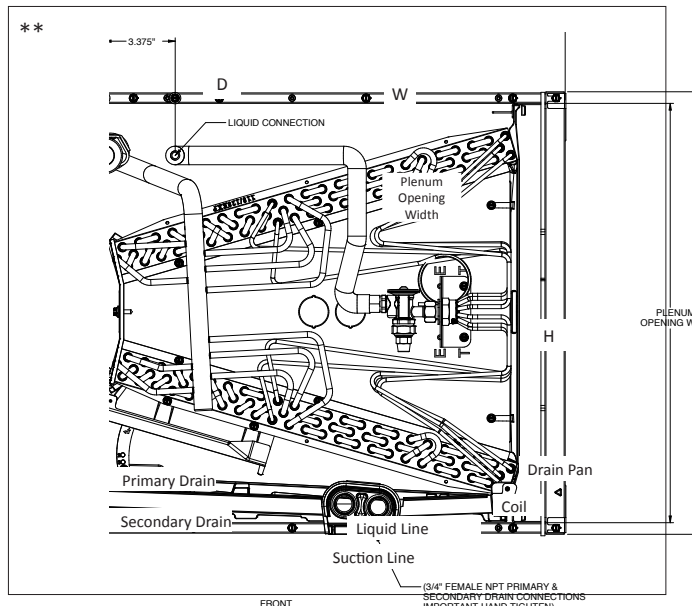
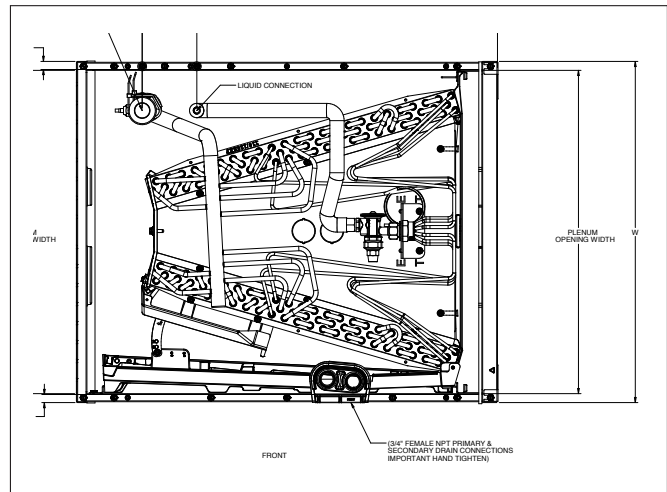
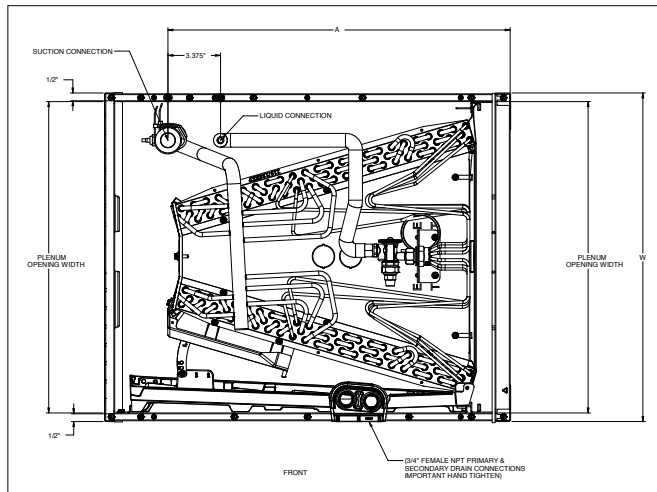

AIRFLOW DATA FOR CAUF, CAUFA & CAPF, CAPFA & CAPEA & CAPE

AIR QUANTITY (SCFM) VS. PRESSURE DROP (IN. WC)

	SCFM	400	500	600	700	800	900	1000	1100	1200	1300	1400	1500
CA*F1824A6*	Wet	0.071	0.099	0.142	0.183	0.230	0.280	0.331	0.389	0.447	0.505	0.563	0.621
	Dry	0.062	0.090	0.122	0.154	0.189	0.231	0.278	0.331	0.390	0.447	0.505	0.563
CA*F1824B6*	Wet	0.021	0.032	0.049	0.071	0.089	0.120	0.128	0.159	0.190	0.221	0.252	0.283
	Dry	0.011	0.022	0.029	0.041	0.052	0.069	0.078	0.101	0.120	0.139	0.158	0.177
CA*F1824C6*	Wet	0.017	0.025	0.043	0.061	0.079	0.107	0.114	0.140	0.164	0.188	0.212	0.236
	Dry	0.011	0.017	0.024	0.035	0.044	0.063	0.075	0.094	0.113	0.132	0.151	0.170
CA*FA1714A6*	Wet	0.120	0.180	0.250	0.330	0.410	0.500	0.600	0.710	0.820	0.930	1.040	1.150
	Dry	0.100	0.150	0.200	0.270	0.340	0.420	0.520	0.610	0.720	0.820	0.930	1.040
CA*FA1714B6*	Wet	0.100	0.150	0.210	0.280	0.340	0.420	0.500	0.580	0.660	0.740	0.820	0.900
	Dry	0.080	0.130	0.170	0.230	0.290	0.360	0.420	0.500	0.650	0.800	0.950	1.100
CA*FA1818A6*/ CA*FA2318A6*	Wet	0.110	0.160	0.220	0.290	0.370	0.460	0.550	0.650	0.760	0.830	0.950	1.080
	Dry	0.074	0.100	0.132	0.168	0.220	0.264	0.317	0.377	0.434	0.503	0.584	0.667
CA*FA1818B6*/ CA*FA2318B6*/ CAPEA1818B4*/ CA*FA1818C6*/ CA*FA2318C6*/	Wet	0.100	0.140	0.190	0.250	0.310	0.380	0.450	0.530	0.610	0.670	0.770	0.870
	Dry	0.066	0.087	0.115	0.144	0.175	0.218	0.260	0.301	0.347	0.401	0.460	0.521
CAPEA1818C4*	Wet	0.093	0.130	0.172	0.221	0.275	0.335	0.400	0.471	0.548	0.631	0.719	0.813
	Dry	0.064	0.086	0.110	0.139	0.170	0.205	0.243	0.284	0.328	0.376	0.427	0.481
CA*FA2422A6*	Wet	0.091	0.128	0.181	0.240	0.304	0.374	0.454	0.541	0.635	0.733	0.837	0.958
	Dry	0.084	0.112	0.148	0.191	0.241	0.299	0.366	0.440	0.522	0.611	0.704	0.803
CA*FA2422B6*/ CAPEA2422B4*/	Wet	0.084	0.117	0.155	0.199	0.249	0.304	0.364	0.430	0.502	0.578	0.661	0.748
	Dry	0.055	0.077	0.102	0.130	0.162	0.196	0.234	0.276	0.320	0.368	0.419	0.473
CA*FA2422C6*/ CAPEA2422C4*/	Wet	0.064	0.091	0.120	0.153	0.189	0.228	0.269	0.314	0.361	0.411	0.464	0.520
	Dry	0.055	0.074	0.095	0.119	0.146	0.175	0.207	0.242	0.280	0.320	0.363	0.408
CA*FA2922A6*	Wet	0.091	0.128	0.181	0.240	0.304	0.374	0.454	0.541	0.635	0.733	0.837	0.958
	Dry	0.084	0.112	0.148	0.191	0.241	0.299	0.366	0.440	0.522	0.611	0.704	0.803
CA*FA2922B6*/ CA*FA2922C6*/	Wet	0.084	0.117	0.155	0.199	0.249	0.304	0.364	0.430	0.502	0.578	0.661	0.748
	Dry	0.055	0.077	0.102	0.130	0.162	0.196	0.234	0.276	0.320	0.368	0.419	0.473
CA*FA3022A6*	Wet	0.091	0.128	0.181	0.240	0.304	0.374	0.454	0.541	0.635	0.733	0.837	0.958
	Dry	0.084	0.112	0.148	0.191	0.241	0.299	0.366	0.440	0.522	0.611	0.704	0.803
CA*FA3022B6*/ CA*FA3022C6*/	Wet	0.084	0.117	0.155	0.199	0.249	0.304	0.364	0.430	0.502	0.578	0.661	0.748
	Dry	0.055	0.077	0.102	0.130	0.162	0.196	0.234	0.276	0.320	0.368	0.419	0.473
CA*FA3022D6*	Wet	0.064	0.091	0.120	0.153	0.189	0.228	0.269	0.314	0.361	0.411	0.464	0.520
	Dry	0.055	0.074	0.095	0.119	0.146	0.175	0.207	0.242	0.280	0.320	0.363	0.408
CA*FA3626B6*/ CAPEA3026B4*/	Wet	0.064	0.089	0.118	0.149	0.184	0.222	0.262	0.306	0.353	0.402	0.455	0.511
	Dry	0.055	0.072	0.092	0.114	0.139	0.167	0.198	0.231	0.267	0.306	0.348	0.392
CA*FA3626C6*/ CAPEA3026C4*/	Wet	0.067	0.085	0.109	0.136	0.167	0.203	0.244	0.288	0.337	0.390	0.447	0.508
	Dry	0.045	0.061	0.080	0.103	0.130	0.159	0.193	0.229	0.269	0.313	0.360	0.410
CA*FA3626D6*/ CAPEA3026D4*/	Wet	0.057	0.079	0.103	0.132	0.163	0.199	0.237	0.280	0.325	0.374	0.427	0.483
	Dry	0.041	0.056	0.072	0.091	0.112	0.134	0.159	0.185	0.214	0.245	0.277	0.312
CA*FA3626E6*/ CAPEA3026E4*/	Wet	0.055	0.076	0.099	0.124	0.152	0.182	0.215	0.250	0.288	0.328	0.370	0.415
	Dry	0.042	0.055	0.070	0.088	0.108	0.130	0.154	0.180	0.208	0.239	0.271	0.306

AIRFLOW DATA FOR CAUF, CAUFA & CAPF, CAPFA & CAPEA & CAPE (CONT.)

AIR QUANTITY (SCFM) VS. PRESSURE DROP (IN. WC)

	SCFM	400	500	600	700	800	900	1000	1100	1200	1300	1400	1500
CA*FA4226B6*	Wet	0.046	0.064	0.087	0.113	0.144	0.171	0.211	0.255	0.299	0.345	0.395	0.450
	Dry	0.015	0.038	0.063	0.089	0.117	0.146	0.180	0.217	0.255	0.297	0.342	0.393
CA*FA4226C6*	Wet	0.059	0.068	0.082	0.100	0.121	0.147	0.176	0.208	0.243	0.281	0.321	0.364
	Dry	0.033	0.046	0.061	0.077	0.095	0.116	0.138	0.162	0.187	0.215	0.244	0.276
CA*FA4226D6*	Wet	0.035	0.055	0.076	0.097	0.118	0.140	0.162	0.186	0.211	0.236	0.262	0.291
	Dry	NA	NA	NA	0.023	0.051	0.078	0.105	0.131	0.157	0.183	0.210	0.237
CA*F3030A6*	Wet	0.151	0.173	0.204	0.238	0.267	0.281	0.326	0.380	0.406	0.451		
	Dry	0.069	0.083	0.117	0.132	0.148	0.183	0.206	0.239	0.290	0.338		
CA*F3030B6*	Wet	0.090	0.120	0.150	0.180	0.210	0.240	0.280	0.330	0.370	0.420		
	Dry	0.080	0.100	0.130	0.150	0.180	0.210	0.250	0.280	0.320	0.360		
CA*F3030C6*	Wet	0.071	0.087	0.120	0.134	0.155	0.180	0.209	0.249	0.284	0.328		
	Dry	0.050	0.067	0.098	0.113	0.135	0.169	0.189	0.213	0.245	0.275		
CA*F3030D6*	Wet	0.069	0.078	0.090	0.108	0.136	0.168	0.206	0.244	0.288	0.337		
	Dry	0.029	0.043	0.070	0.082	0.098	0.125	0.141	0.153	0.177	0.200		
CA*F3131B26*	Wet	0.041	0.049	0.061	0.078	0.090	0.113	0.131	0.140	0.162	0.178	0.210	
	Dry	0.021	0.031	0.039	0.048	0.061	0.072	0.079	0.091	0.110	0.122	0.141	
CA*F3131C6*	Wet	0.035	0.036	0.038	0.051	0.059	0.073	0.087	0.094	0.110	0.125	0.145	
	Dry	0.014	0.022	0.028	0.036	0.045	0.054	0.061	0.068	0.081	0.091	0.108	
CA*F31317B6*	Wet	0.090	0.110	0.140	0.170	0.200	0.230	0.270	0.300	0.350	0.390	0.440	0.5
	Dry	0.080	0.100	0.130	0.160	0.190	0.220	0.250	0.290	0.340	0.380	0.430	0.48
CA*F3636A6*	Wet	0.135	0.170	0.220	0.280	0.310	0.380	0.450	0.530	0.610	0.690	0.790	0.870
	Dry	0.130	0.160	0.200	0.230	0.280	0.320	0.380	0.450	0.520	0.590	0.670	0.710
CA*F3636B6*	Wet	0.115	0.135	0.170	0.180	0.220	0.260	0.300	0.350	0.400	0.460	0.520	0.570
	Dry	0.110	0.130	0.160	0.170	0.210	0.240	0.270	0.330	0.370	0.420	0.470	0.520
CA*F3636C6*	Wet	0.100	0.120	0.160	0.170	0.210	0.250	0.290	0.340	0.380	0.430	0.480	0.540
	Dry	0.090	0.110	0.130	0.140	0.160	0.180	0.220	0.250	0.280	0.320	0.350	0.370
CA*F3636D6*	Wet	0.095	0.115	0.140	0.150	0.170	0.200	0.230	0.270	0.310	0.350	0.390	0.430
	Dry	0.090	0.110	0.130	0.140	0.160	0.190	0.220	0.240	0.270	0.300	0.340	0.380
CA*F3636E6*	Wet	0.135	0.170	0.220	0.280	0.310	0.380	0.450	0.530	0.610	0.690	0.790	0.870
	Dry	0.130	0.160	0.200	0.230	0.280	0.320	0.380	0.450	0.520	0.590	0.670	0.710
CA*F3636F6*	Wet	0.115	0.135	0.170	0.180	0.220	0.260	0.300	0.350	0.400	0.460	0.520	0.570
	Dry	0.110	0.130	0.160	0.170	0.210	0.240	0.270	0.330	0.370	0.420	0.470	0.520
CA*F3636G6*	Wet	0.100	0.120	0.160	0.170	0.210	0.250	0.290	0.340	0.380	0.430	0.480	0.540
	Dry	0.090	0.110	0.130	0.140	0.160	0.180	0.220	0.250	0.280	0.320	0.350	0.370
CA*F3636H6*	Wet	0.095	0.115	0.140	0.150	0.170	0.200	0.230	0.270	0.310	0.350	0.390	0.430
	Dry	0.090	0.110	0.130	0.140	0.160	0.190	0.220	0.240	0.270	0.300	0.340	0.380
CA*F3636I6*	Wet	0.135	0.170	0.220	0.280	0.310	0.380	0.450	0.530	0.610	0.690	0.790	0.870
	Dry	0.130	0.160	0.200	0.230	0.280	0.320	0.380	0.450	0.520	0.590	0.670	0.710
CA*F3636J6*	Wet	0.115	0.135	0.170	0.180	0.220	0.260	0.300	0.350	0.400	0.460	0.520	0.570
	Dry	0.110	0.130	0.160	0.170	0.210	0.240	0.270	0.330	0.370	0.420	0.470	0.520
CA*F3636K6*	Wet	0.100	0.120	0.160	0.170	0.210	0.250	0.290	0.340	0.380	0.430	0.480	0.540
	Dry	0.090	0.110	0.130	0.140	0.160	0.180	0.220	0.250	0.280	0.320	0.350	0.370
CA*F3636L6*	Wet	0.095	0.115	0.140	0.150	0.170	0.200	0.230	0.270	0.310	0.350	0.390	0.430
	Dry	0.090	0.110	0.130	0.140	0.160	0.190	0.220	0.240	0.270	0.300	0.340	0.380
CA*F3636M6*	Wet	0.135	0.170	0.220	0.280	0.310	0.380	0.450	0.530	0.610	0.690	0.790	0.870
	Dry	0.130	0.160	0.200	0.230	0.280	0.320	0.380	0.450	0.520	0.590	0.670	0.710
CA*F3636N6*	Wet	0.115	0.135	0.170	0.180	0.220	0.260	0.300	0.350	0.400	0.460	0.520	0.570
	Dry	0.110	0.130	0.160	0.170	0.210	0.240	0.270	0.330	0.370	0.420	0.470	0.520
CA*F3636O6*	Wet	0.100	0.120	0.160	0.170	0.210	0.250	0.290	0.340	0.380	0.430	0.480	0.540
	Dry	0.090	0.110	0.130	0.140	0.160	0.180	0.220	0.250	0.280	0.320	0.350	0.370
CA*F3636P6*	Wet	0.095	0.115	0.140	0.150	0.170	0.200	0.230	0.270	0.310	0.350	0.390	0.430
	Dry	0.090	0.110	0.130	0.140	0.160	0.190	0.220	0.240	0.270	0.300	0.340	0.380
CA*F3636Q6*	Wet	0.135	0.170	0.220	0.280	0.310	0.380	0.450	0.530	0.610	0.690	0.790	0.870
	Dry	0.130	0.160	0.200	0.230	0.280	0.320	0.380	0.450	0.520	0.590	0.670	0.710
CA*F3636R6*	Wet	0.115	0.135	0.170	0.180	0.220	0.260	0.300	0.350	0.400	0.460	0.520	0.570
	Dry	0.110	0.130	0.160	0.170	0.210	0.240	0.270	0.330	0.370	0.420	0.470	0.520
CA*F3636S6*	Wet	0.100	0.120	0.160	0.170	0.210	0.250	0.290	0.340	0.380	0.430	0.480	0.540
	Dry	0.090	0.110	0.130	0.140	0.160	0.180	0.220	0.250	0.280	0.320	0.350	0.370
CA*F3636T6*	Wet	0.095	0.115	0.140	0.150	0.170	0.200	0.230	0.270	0.310	0.350	0.390	0.430
	Dry	0.090	0.110	0.130	0.140	0.160	0.190	0.220	0.240	0.270	0.300	0.340	0.380
CA*F3636U6*	Wet	0.135	0.170	0.220	0.280	0.310	0.380	0.450	0.530	0.610	0.690	0.790	0.870
	Dry	0.130	0.160	0.200	0.230	0.280	0.320	0.380	0.450	0.520	0.590	0.670	0.710
CA*F3636V6*	Wet	0.115	0.135	0.170	0.180	0.220	0.260	0.300	0.350	0.400	0.460	0.520	0.570
	Dry	0.110	0.130	0.160	0.170	0.210	0.240	0.270	0.330	0.370	0.420	0.470	0.520
CA*F3636W6*	Wet	0.100	0.120	0.160	0.170	0.210	0.250	0.290	0.340	0.380	0.430	0.480	0.540
	Dry	0.090	0.110	0.130	0.140	0.160	0.180	0.220	0.250	0.280	0.320	0.350	0.370
CA*F3636X6*	Wet	0.095	0.115	0.140	0.150	0.170	0.200	0.230	0.270	0.310	0.350	0.390	0.430
	Dry	0.090	0.110	0.130	0.140	0.160	0.190	0.220	0.240	0.270	0.300	0.340	0.380
CA*F3636Y6*	Wet	0.135	0.170	0.220	0.280	0.310	0.380	0.450	0.530	0.610	0.690	0.790	0.870
	Dry	0.130	0.160	0.200	0.230	0.280	0.320	0.380	0.450	0.520	0.590	0.670	0.710
CA*F3636Z6*	Wet	0.115	0.135	0.170	0.180	0.220	0.260	0.300	0.350	0.400	0.460	0.520	0.570
	Dry	0.110	0.130	0.160	0.170	0.210	0.240	0.270	0.330	0.370	0.420	0.470	0.520

AIRFLOW DATA FOR CAPT

AIR QUANTITY (SCFM) VS. PRESSURE DROP (IN. WC)

	SCFM	600		700		800		900		1000		1100		1200		1300		1400		1500		1600		
		Wet	Dry	Wet	Dry	Wet	Dry	Wet	Dry	Wet	Dry	Wet	Dry	Wet	Dry	Wet	Dry	Wet	Dry	Wet	Dry	Wet	Dry	
CAPT3131B4*	Wet	0.041	0.049	0.061	0.078	0.090	0.113	0.131	0.140	0.162	0.178	0.210												
	Dry	0.021	0.031	0.039	0.048	0.061	0.072	0.079	0.091	0.110	0.122	0.141												
CAPT3131C4*	Wet	0.035	0.036	0.038	0.051	0.059	0.073	0.087	0.094	0.110	0.125	0.145												
	Dry	0.014	0.022	0.028	0.036	0.045	0.054	0.061	0.068	0.081	0.091	0.108												
	SCFM	800	900	1000	1100	1200	1300	1400	1500	1600	1700	1800	1900	2000	2100	2200								
	Wet	0.083	0.093	0.113	0.133	0.143	0.163	0.183	0.213	0.243	0.263	0.293	0.323	0.353	0.383	0.423								
CAPT3743C4*	Dry	0.073	0.083	0.103	0.113	0.133	0.153	0.163	0.193	0.213	0.233	0.263	0.293	0.313	0.343	0.373								
	Wet	0.074	0.080	0.089	0.107	0.120	0.129	0.138	0.169	0.188	0.209	0.229	0.251	0.273	0.279	0.306								
CAPT3743D4*	Dry	0.046	0.056	0.070	0.076	0.086	0.107	0.110	0.126	0.147	0.160	0.176	0.196	0.210	0.230	0.253								
	SCFM	1000	1100	1200	1300	1400	1500	1600	1700	1800	1900	2000	2100	2200										
CAPT4961C4*	Wet	0.209	0.233	0.255	0.286	0.308	0.341	0.397	0.412	0.455	0.496	0.540	0.628	0.643										
	Dry	0.202	0.219	0.236	0.248	0.288	0.300	0.306	0.315	0.332	0.351	0.406	0.431	0.604										
CAPT4961D4*	Wet	0.140	0.158	0.179	0.198	0.228	0.249	0.277	0.300	0.329	0.351	0.397	0.462	0.487										
	Dry	0.128	0.140	0.159	0.178	0.189	0.202	0.206	0.212	0.232	0.252	0.282	0.302	0.419										

AIRFLOW DATA FOR CAPTA

AIR QUANTITY (SCFM) VS. PRESSURE DROP (IN. WC)

	SCFM	400	500	600	700	800	900	1000	1100	1200
CAPTA1818A4**	Wet	0.080	0.135	0.205	0.275	0.346	0.422	0.516	0.620	0.715
	Dry	0.074	0.115	0.180	0.239	0.297	0.368	0.443	0.543	0.638
CAPTA1818B4**	Wet	0.067	0.106	0.165	0.215	0.261	0.317	0.372	0.425	0.482
	Dry	0.050	0.087	0.125	0.175	0.215	0.265	0.319	0.381	0.444
	SCFM	500	600	700	800	900	1000	1100	1200	1300
CAPTA2422A4**	Wet	0.108	0.150	0.195	0.250	0.310	0.379	0.460	0.543	0.625
	Dry	0.088	0.125	0.170	0.215	0.265	0.320	0.385	0.440	0.535
CAPTA2422B4**	Wet	0.090	0.130	0.150	0.220	0.250	0.310	0.369	0.436	0.508
	Dry	0.082	0.100	0.140	0.170	0.210	0.260	0.300	0.350	0.410
CAPTA2422C4**	Wet	0.091	0.110	0.139	0.172	0.205	0.245	0.285	0.335	0.387
	Dry	0.069	0.084	0.111	0.133	0.162	0.185	0.210	0.250	0.295
	SCFM	600	700	800	900	1000	1100	1200	1300	1400
CAPTA3022A4**	Wet	0.150	0.195	0.250	0.310	0.379	0.460	0.543	0.625	0.730
	Dry	0.125	0.170	0.215	0.265	0.320	0.385	0.440	0.535	0.618
CAPTA3022B4**	Wet	0.130	0.150	0.220	0.250	0.310	0.369	0.436	0.508	0.584
	Dry	0.100	0.140	0.170	0.210	0.260	0.300	0.350	0.410	0.480
CAPTA3022C4**	Wet	0.110	0.139	0.172	0.205	0.245	0.285	0.335	0.387	0.437
	Dry	0.084	0.111	0.133	0.162	0.185	0.210	0.250	0.295	0.330
CAPTA3026B4**	Wet	0.115	0.150	0.190	0.229	0.270	0.310	0.365	0.420	0.475
	Dry	0.096	0.122	0.150	0.183	0.215	0.252	0.292	0.334	0.382
CAPTA3026C4**	Wet	0.090	0.110	0.140	0.170	0.200	0.240	0.280	0.320	0.370
	Dry	0.080	0.100	0.120	0.150	0.180	0.210	0.240	0.260	0.300
	SCFM	800	900	1000	1100	1200	1300	1400	1500	1600
CAPTA3626B4**	Wet	0.134	0.167	0.204	0.245	0.290	0.338	0.389	0.444	0.485
	Dry	0.127	0.157	0.190	0.229	0.269	0.316	0.360	0.415	0.450
CAPTA3626C4**	Wet	0.100	0.120	0.150	0.180	0.210	0.240	0.280	0.310	0.360
	Dry	0.080	0.100	0.130	0.150	0.170	0.200	0.230	0.270	0.300
	SCFM	1000	1100	1200	1300	1400	1500	1600	1700	1800
CAPTA4230C4**	Wet	0.130	0.150	0.180	0.210	0.250	0.280	0.310	0.340	0.378
	Dry	0.110	0.132	0.156	0.181	0.208	0.237	0.270	0.300	0.335
CAPTA4230D4**	Wet	0.120	0.140	0.160	0.190	0.220	0.250	0.280	0.310	0.350
	Dry	0.091	0.109	0.127	0.147	0.160	0.190	0.210	0.230	0.260
										1900
										0.414
										0.372
										0.380
										0.280

AIRFLOW DATA FOR CHPTA AND CHPT

AIR QUANTITY (SCFM) VS. PRESSURE DROP (IN. WC)

	SCFM	400	500	600	700	800	900	1000	1100	1200	1300	1400		
CHPTA 1822A4**	Wet	0.095	0.151	0.215	0.284	0.354	0.429	0.519	0.601					
	Dry	0.064	0.094	0.144	0.199	0.284	0.353	0.431	0.513					
CHPTA 1822B4**	Wet	0.090	0.120	0.140	0.190	0.250	0.310	0.390	0.460					
	Dry	0.080	0.110	0.130	0.180	0.230	0.290	0.360	0.430					
	SCFM	500	600	700	800	900	1000	1100	1200	1300				
CHPTA 2426B4**	Wet	0.13	0.150	0.180	0.204	0.255	0.304	0.365	0.419	0.468				
	Dry	0.10	0.120	0.150	0.170	0.210	0.240	0.290	0.330	0.410				
CHPTA 2426C4**	Wet	0.11	0.140	0.160	0.180	0.200	0.230	0.270	0.320	0.370				
	Dry	0.09	0.110	0.130	0.150	0.190	0.220	0.260	0.300	0.350				
	SCFM	600	700	800	900	1000	1100	1200	1300	1400				
CHPTA 3026B4**	Wet	0.11	0.150	0.180	0.230	0.280	0.320	0.370	0.430	0.490				
	Dry	0.12	0.140	0.170	0.210	0.250	0.290	0.340	0.400	0.460				
CHPTA 3026C4**	Wet	0.1	0.130	0.150	0.170	0.200	0.230	0.260	0.300	0.340				
	Dry	0.06	0.080	0.110	0.130	0.150	0.174	0.198	0.229	0.259				
	SCFM	800	900	1000	1100	1200	1300	1400	1500					
CHPTA 3630B4**	Wet	0.15	0.187	0.229	0.279	0.323	0.372	0.43	0.465					
	Dry	0.128	0.153	0.191	0.237	0.285	0.33	0.377	0.428					
CHPTA 3630C4**	Wet	0.14	0.175	0.205	0.245	0.285	0.325	0.365	0.41					
	Dry	0.086	0.105	0.135	0.155	0.185	0.21	0.245	0.279					
	SCFM	1000	1100	1200	1300	1400	1500	1600	1700	1800	1900	2000	2100	2200
CHPT 4860D4**	Wet	0.126	0.150	0.175	0.200	0.230	0.265	0.295	0.325	0.355	0.395	0.433	0.449	0.467
	Dry	0.12	0.137	0.164	0.186	0.215	0.246	0.278	0.315	0.341	0.379	0.409	0.472	0.514

AIRFLOW DATA FOR CHPF AND CHPE

AIR QUANTITY (SCFM) VS. PRESSURE DROP (IN. WC)

	SCFM	600	700	800	900	1000	1100	1200	1300	1400						
CHPF1824A6*	Wet	0.132	0.179	0.222	0.272	0.327	0.381	0.456	0.522	0.605						
	Dry	0.126	0.165	0.206	0.249	0.302	0.354	0.414	0.478	0.563						
	SCFM	600	700	800	900	1000	1100	1200	1300	1400	1500	1600				
CHPF2430B6*	Wet	0.106	0.124	0.152	0.184	0.218	0.258	0.301	0.350	0.406	0.460	0.514				
	Dry	0.101	0.122	0.145	0.174	0.209	0.247	0.288	0.333	0.381	0.428	0.484				
CHPE2430B4*	Wet	0.106	0.124	0.152	0.184	0.218	0.258	0.301	0.350	0.406	0.460	0.514				
	Dry	0.101	0.122	0.145	0.174	0.209	0.247	0.288	0.333	0.381	0.428	0.484				
	SCFM	600	700	800	900	1000	1100	1200	1300	1400	1500	1600				
CHPF3636B6*	Wet	0.107	0.131	0.167	0.199	0.239	0.291	0.338	0.389	0.439	0.494	0.552				
	Dry	0.102	0.126	0.152	0.184	0.220	0.259	0.303	0.349	0.401	0.458	0.516				
CHPE3636B4*	Wet	0.107	0.131	0.167	0.199	0.239	0.291	0.338	0.389	0.439	0.494	0.552				
	Dry	0.102	0.126	0.152	0.184	0.220	0.259	0.303	0.349	0.401	0.458	0.516				
	SCFM	800	900	1000	1100	1200	1300	1400	1500	1600	1700	1800	1900	2000	2100	2200
CHPF3642C6*	Wet	0.083	0.103	0.126	0.151	0.178	0.208	0.240	0.274	0.310	0.346	0.383	---	---	---	---
	Dry	0.073	0.096	0.120	0.144	0.169	0.196	0.224	0.254	0.286	0.319	0.354	---	---	---	---
CHPE3642C4*	Wet	0.083	0.103	0.126	0.151	0.178	0.208	0.240	0.274	0.310	0.346	0.383	---	---	---	---
	Dry	0.073	0.096	0.120	0.144	0.169	0.196	0.224	0.254	0.286	0.319	0.354	---	---	---	---
CHPF3642D6*	Wet	0.040	0.050	0.060	0.070	0.080	0.080	0.090	0.100	0.110	0.120	0.120	0.130	0.150	0.160	0.180
	Dry	0.030	0.040	0.040	0.050	0.060	0.070	0.080	0.085	0.090	0.100	0.110	0.120	0.140	0.150	0.160
CHPE3642D4*	Wet	0.040	0.050	0.060	0.070	0.080	0.080	0.090	0.100	0.110	0.120	0.120	0.130	0.150	0.160	0.180
	Dry	0.030	0.040	0.040	0.050	0.060	0.070	0.080	0.085	0.090	0.100	0.110	0.120	0.140	0.150	0.160
	SCFM	800	900	1000	1100	1200	1300	1400	1500	1600	1700	1800	1900	2000	2100	2200
CHPF3743C6*	Wet	0.133	0.153	0.176	0.201	0.228	0.258	0.290	0.324	0.360	0.396	0.433	---	---	---	---
	Dry	0.123	0.146	0.170	0.194	0.219	0.246	0.274	0.304	0.336	0.369	0.404	---	---	---	---
CHPE3743C4*	Wet	0.133	0.153	0.176	0.201	0.228	0.258	0.290	0.324	0.360	0.396	0.433	---	---	---	---
	Dry	0.123	0.146	0.170	0.194	0.219	0.246	0.274	0.304	0.336	0.369	0.404	---	---	---	---
CHPF3743D4*	Wet	0.101	0.105	0.115	0.125	0.145	0.165	0.195	0.215	0.235	0.265	0.295	0.315	0.355	0.375	0.405
	Dry	0.072	0.095	0.105	0.115	0.135	0.155	0.185	0.205	0.225	0.255	0.275	0.305	0.335	0.365	0.395
CHPE3743D4*	Wet	0.101	0.105	0.115	0.125	0.145	0.165	0.195	0.215	0.235	0.265	0.295	0.315	0.355	0.375	0.405
	Dry	0.072	0.095	0.105	0.115	0.135	0.155	0.185	0.205	0.225	0.255	0.275	0.305	0.335	0.365	0.395
	SCFM	900	1000	1100	1200	1300	1400	1500	1600	1700	1800	1900	2000	2100	2200	
CHPF4860D6*	Wet	0.111	0.131	0.151	0.171	0.191	0.211	0.231	0.261	0.291	0.321	0.361	0.391	0.431	0.471	
	Dry	0.101	0.121	0.141	0.161	0.181	0.201	0.221	0.251	0.281	0.311	0.341	0.371	0.411	0.441	
CHPE4860D4*	Wet	0.111	0.131	0.151	0.171	0.191	0.211	0.231	0.261	0.291	0.321	0.361	0.391	0.431	0.471	
	Dry	0.101	0.121	0.141	0.161	0.181	0.201	0.221	0.251	0.281	0.311	0.341	0.371	0.411	0.441	

AIRFLOW DATA FOR CSCF

AIR QUANTITY (SCFM) VS. PRESSURE DROP (IN. WC)

	SCFM	500	600	700	800	900	1000	1100	1200										
CSCF1824N6D*	Wet	0.104	0.143	0.176	0.212	0.255	0.292	0.321	0.344										
	Dry	0.048	0.067	0.086	0.108	0.132	0.159	0.186	0.206										
	SCFM			700	800	900	1000	1100	1200	1300	1400								
CSCF3036N6D*	Wet	---	---	0.062	0.076	0.092	0.109	0.131	0.156	0.186	0.209								
	Dry	---	---	0.032	0.043	0.055	0.068	0.082	0.099	0.114	0.131								
CSCF3642N6D*	Wet	---	---	---	0.045	0.063	0.081	0.099	0.116	0.132	0.148	0.166	0.183	0.202	0.220	0.236	0.259	0.278	0.291
	Dry	---	---	---	0.039	0.051	0.064	0.077	0.092	0.105	0.121	0.138	0.150	0.175	0.191	0.214	0.230	0.251	0.262
	SCFM			800	900	1000	1100	1200	1300	1400	1500	1600	1700	1800	1900	2000	2100	2200	
CSCF4860N6D*	Wet	---	---	---	0.051	0.068	0.085	0.103	0.120	0.137	0.154	0.173	0.192	0.212	0.233	0.255	0.278	0.299	0.319
	Dry	---	---	---	0.043	0.056	0.069	0.084	0.099	0.115	0.132	0.149	0.167	0.185	0.207	0.227	0.249	0.272	0.282**

** Maximum SCFM = 2146

ACCESSORIES

EXPANSION VALVE KITS FOR NON-TXV, NON-EEV COILS

KIT NUMBER	DESCRIPTION	APPLICATION	REFRIGERANT	TONNAGE: OUTDOOR UNIT
TXV-30 ²	Non-bleed Valve	AC Only	R-410A	1½- 2½ Ton
TXV-42 ²	Non-bleed Valve	AC Only	R-410A	3- 3½ Ton
TXV-48 ²	Non-bleed Valve	AC Only	R-410A	4 Ton
TXV-60 ²	Non-bleed Valve	AC Only	R-410A	5 Ton
TX2N4A	Non-bleed Valve	AC or HP	R-410A	1½- 2 Ton
TX3N4	Non-bleed Valve	AC or HP	R-410A	2½- 3 Ton
TX5N4	Non-bleed Valve	AC or HP	R-410A	3½- 5 Ton

Note: Condensing units and heat pumps with reciprocating compressors require the use of start-assist components when used in conjunction with an indoor coil using a non-bleed thermal expansion valve refrigerant metering device.

HIGH-TEMP DRAIN PAN KITS FOR CAUF, CAPF AND CAPT

DRAIN PAN KITS	FURNACE SIZE
HTP-A	14" furnaces
HTP-B	17½" furnaces
HTP-C	21" furnaces
HTP-D	24½" furnaces

DRAIN PAN INSULATION KITS FOR CAPEA, CAPTA, CAPFA, & CAUFA

KIT NUMBER	CABINET WIDTH
DPICX-AB	14"
DPICX-BB	17½"
DPICX-CB	21"
DPICX-DB	24½"

DRAIN PAN INSULATION KITS FOR CAPE

KIT NUMBER	CABINET WIDTH
(a) DPICX-C (b) DPICX-CA	21"
(a) DPICX-D (b) DPICX-DA	24½"

* (a) and (b) are compatible.
(a) being used to depletion (a) by replaced (b).

DOWNFLOW KIT FOR CAPE

KIT NUMBER	CABINET WIDTH
DFKE-001	21" , 24½"

HORIZONTAL RIGHT COIL ACCESSORY FOR HIGH HUMIDITY ENVIRONMENT FOR CHPTA

KIT NUMBER	CABINET WIDTH
HHCMK01	All Horizontal cabinets

HIGH-TEMP DRAIN PAN KITS FOR CAUFA, CAPFA, CAPTA AND CAPEA

DRAIN PAN KITS	FURNACE SIZE
HTP7-A	14" Furnaces
HTP7-B	17½" furnaces
HTP7-C	21" furnace
HTP7-D	24½" furnaces